



INTERMEDIATE | 1 DAY CLASS

WINTER'S ZEN GARDEN

Finished Quilt: 67" x 88"

Quilt design by
Georgie Gerl & Tiffany Moler,
featuring Baby It's Cold Outside.

It's time to be still, as Nature takes her long nap. Georgie's design captures the serenity of the season by framing the elegantly minimalist artwork.

Q4412 4S-Black Silver	Q4412 3S-White Silver
Q7646 3S-White Silver	Q4416 3S-White Silver
Q7647 619S-Warm Gray Silver	Q7646 190S-Ice Blue Silver
Q7648 3S-White Silver	Q7647 128S-Midnight Silver
Q7649 126S-Birch Silver	Q7648 190S-Ice Blue Silver
Q7650 126S-Birch Silver	Q7649 3S-White Silver
P4323 92S-Slate Silver	Q7650 3S-White Silver
P4324 5S-Red Silver	P4323 92S-Slate Silver
L7360 4S-Black Silver	L7360 76S-Pewter Silver
L7360 134S-Parchment Silver	L7360 78S-Scarlet Silver
L7360 307S-Snow Silver	G8555 19S-Navy Silver

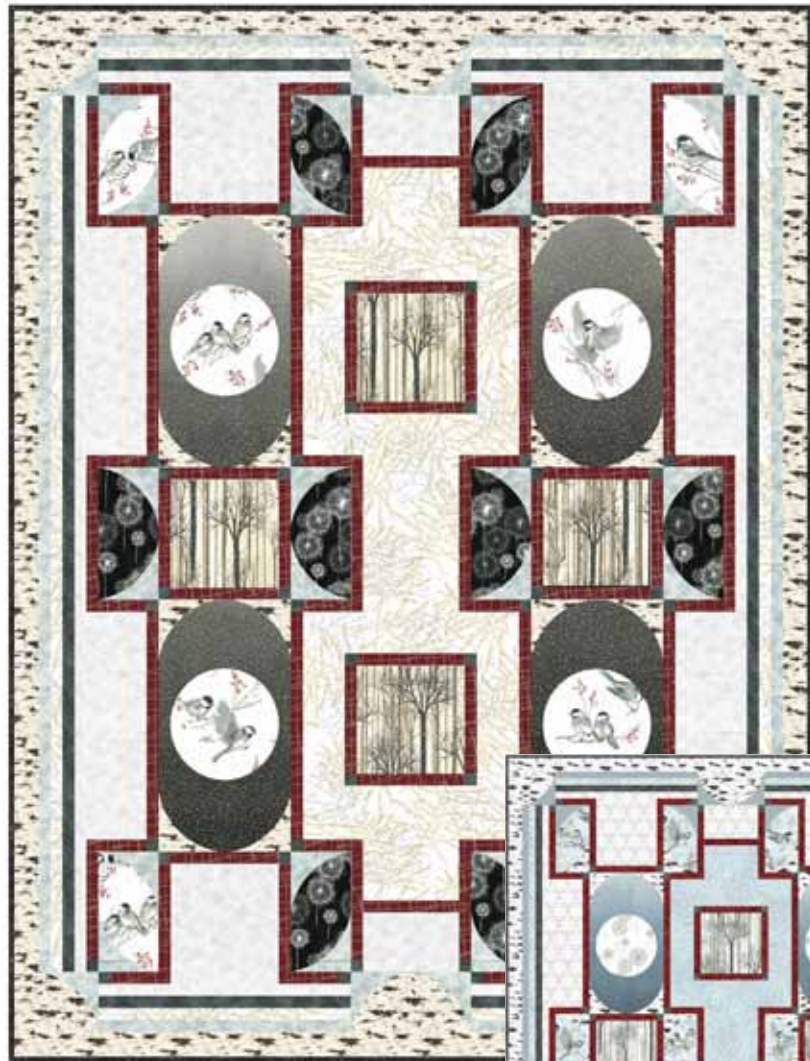

White Colorway

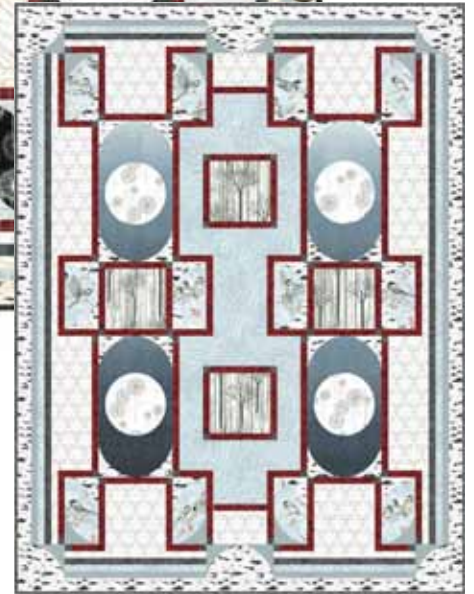

Blue Colorway

WHITE	1 KIT
Q4412 4S-Black Silver	3/4 Yard
Q7646 3S-White Silver	1 Yard
Q7647 619S-Warm Gray Silver	1 3/8 Yards
Q7648 3S-White Silver	1 3/8 Yards
Q7649 126S-Birch Silver	1 1/4 Yards
Q7650 126S-Birch Silver	1/2 Yard
P4323 92S-Slate Silver	2/3 Yard
P4324 5S-Red Silver	1 Yard
L7360 4S-Black Silver	7/8 Yard*
L7360 134S-Parchment Silver	1 1/8 Yards
L7360 307S-Snow Silver	1 3/8 Yards

* binding

BLUE	1 KIT
Q4412 3S-White Silver	3/4 Yard
Q4416 3S-White Silver	1 1/8 Yards
Q7646 190S-Ice Blue Silver	1 Yard
Q7647 128S-Midnight Silver	1 3/8 Yards
Q7648 190S-Ice Blue Silver	1 3/8 Yards
Q7649 3S-White Silver	1 1/4 Yards
Q7650 3S-White Silver	1/2 Yard
P4323 92S-Slate Silver	1 3/8 Yards
L7360 76S-Pewter Silver	2/3 Yard
L7360 78S-Scarlet Silver	1 Yard
G8555 19S-Navy Silver	7/8 Yard*

FREE PATTERN DOWNLOAD
hoffmanfabrics.com



Winter Zen Garden Quilt

冬

67" x 88"

An early morning stroll through the garden brings serenity while listening to the sweet music sung by these birds.

Quilt Designers
Tiffany Moler
& Georgie Gerl

Featuring
Hoffman Fabrics
Baby it's Cold Outside
Fabric Line



Winter Zen Garden Quilt Layout

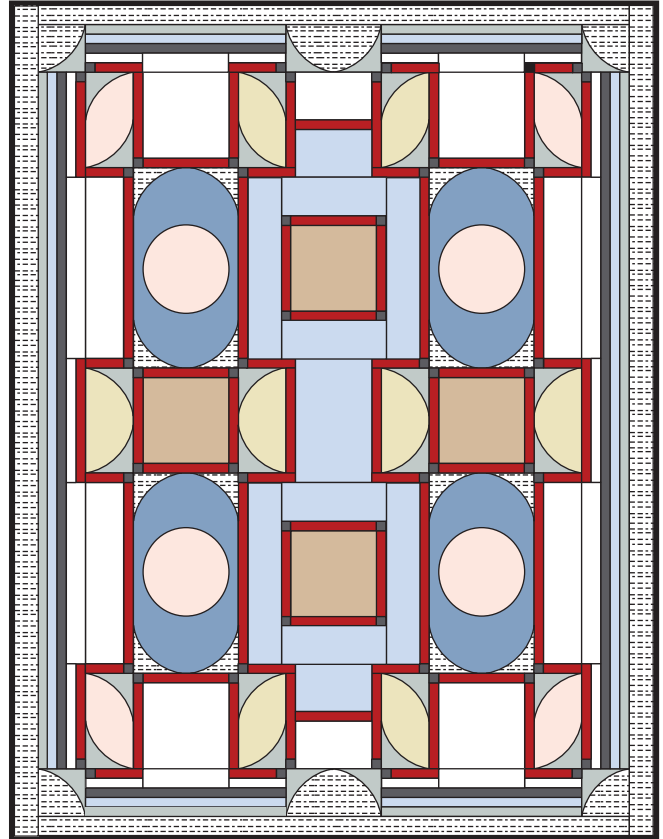

Fabric A Q7648 190S Ice Blue Silver Center Background— $1\frac{3}{8}$ yards (Cut one $4\frac{1}{2}$ " x $11\frac{1}{2}$ " strip from remaining $5\frac{1}{2}$ " strip.)	First Cuts		Next Cuts	
	1	$8\frac{1}{2}$ " x 42"	1	$8\frac{1}{2}$ " x $13\frac{1}{2}$ "
	1	$5\frac{1}{2}$ " x 42"	2	$5\frac{1}{2}$ " x $8\frac{1}{2}$ "
	1	$4\frac{1}{2}$ " x 42"	4	$4\frac{1}{2}$ " x $11\frac{1}{2}$ "
	2	4" x 42"	4	4" x $19\frac{1}{2}$ "
	8	$1\frac{1}{2}$ " x 42"	4	$1\frac{1}{2}$ " x $21\frac{1}{2}$ "

Fabric B Q7647 128S Midnight Silver Circle Background— $1\frac{3}{8}$ yards	Cuts	
	4	$11\frac{1}{2}$ " x $21\frac{1}{2}$ "

Fabric C Q4416 3S White Silver Quilt Background $1\frac{1}{8}$ yards	First Cuts		Next Cuts	
	1	$19\frac{1}{2}$ " x 42"	4	$19\frac{1}{2}$ " x $4\frac{1}{2}$ "
			4	$9\frac{1}{2}$ " squares
	1	$5\frac{1}{2}$ " x 42"	2	$5\frac{1}{2}$ " x $8\frac{1}{2}$ "
	2	$2\frac{1}{2}$ " x 42"	4	$2\frac{1}{2}$ " x $9\frac{1}{2}$ "
	3	$1\frac{1}{2}$ " x 42"	2	$1\frac{1}{2}$ " x $19\frac{1}{2}$ "
		4	$1\frac{1}{2}$ " x $13\frac{1}{2}$ "	
		4	$1\frac{1}{2}$ " x $11\frac{1}{2}$ "	
		8	$1\frac{1}{2}$ " x $6\frac{1}{2}$ "	

Fabric D Q7650 3S White Silver Tree Blocks $\frac{1}{2}$ yard	Cuts	
	4	$9\frac{1}{2}$ " squares "Fussy Cut"

Fabric E Q7646 190S Ice Blue Silver Circles & Small Blocks 1 yard	Cuts	
	4	$10\frac{1}{2}$ " x $5\frac{1}{2}$ " "Fussy Cut"
	4	9" circles "Fussy Cut" <i>Refer to page 5 for circle cutting instructions.</i>

Fabric F Q4412 3S-White-Silver Small Blocks $\frac{3}{4}$ yard "Fussy Cut"	First Cuts		Next Cuts	
	1	$11\frac{1}{2}$ " x 42"	4	$11\frac{1}{2}$ " x $5\frac{1}{2}$ "
	1	$10\frac{1}{2}$ " x 42"	4	$10\frac{1}{2}$ " x $5\frac{1}{2}$ "

Fabric G P4323 92S Slate Silver Small Blocks & Border $1\frac{3}{8}$ yards	First Cuts		Next Cuts	
	5	$5\frac{1}{2}$ " x 42"	32	$5\frac{1}{2}$ " squares
	8	$1\frac{1}{2}$ " x 42"	4	$1\frac{1}{2}$ " x $21\frac{1}{2}$ "

Fabric J 7649 3S White Silver Outside Border $1\frac{1}{4}$ yard	First Cuts		Next Cuts	
	4	45" x $2\frac{1}{2}$ "	(45" runs parallel to selvage)	
	6	$2\frac{1}{2}$ " x 27"		
	2	$5\frac{1}{2}$ " x $10\frac{1}{2}$ "		
	20	$5\frac{1}{2}$ " squares		

Fabric H L7360 76S Pewter Silver Sashing Accents & Border $\frac{2}{3}$ yard	First Cuts		Next Cuts	
	11	$1\frac{1}{2}$ " x 42"	4	$1\frac{1}{2}$ " x $21\frac{1}{2}$ "
		56	$1\frac{1}{2}$ " squares	

Lining (backing for Appliqué circles)— $\frac{2}{3}$ yard *Lining does not show.* **Backing**— $5\frac{1}{3}$ yards
Batting—75" x 96"

Fabric I L7360 78S Scarlet Silver Sashing 1 yard	First Cuts		Next Cuts	
	20	$1\frac{1}{2}$ " x 42"	8	$1\frac{1}{2}$ " x $19\frac{1}{2}$ "
			2	$1\frac{1}{2}$ " x $13\frac{1}{2}$ "
			4	$1\frac{1}{2}$ " x $11\frac{1}{2}$ "
			8	$1\frac{1}{2}$ " x $10\frac{1}{2}$ "
			28	$1\frac{1}{2}$ " x $9\frac{1}{2}$ "
			2	$1\frac{1}{2}$ " x $8\frac{1}{2}$ "
			16	$1\frac{1}{2}$ " x $5\frac{1}{2}$ "
		8	$1\frac{1}{2}$ " x $4\frac{1}{2}$ "	

Fabric K G8555 19S Navy Silver Binding— $\frac{7}{8}$ yard	Cuts	
	8	$2\frac{3}{4}$ " x 42"

Winter Zen Garden Quilt Layout

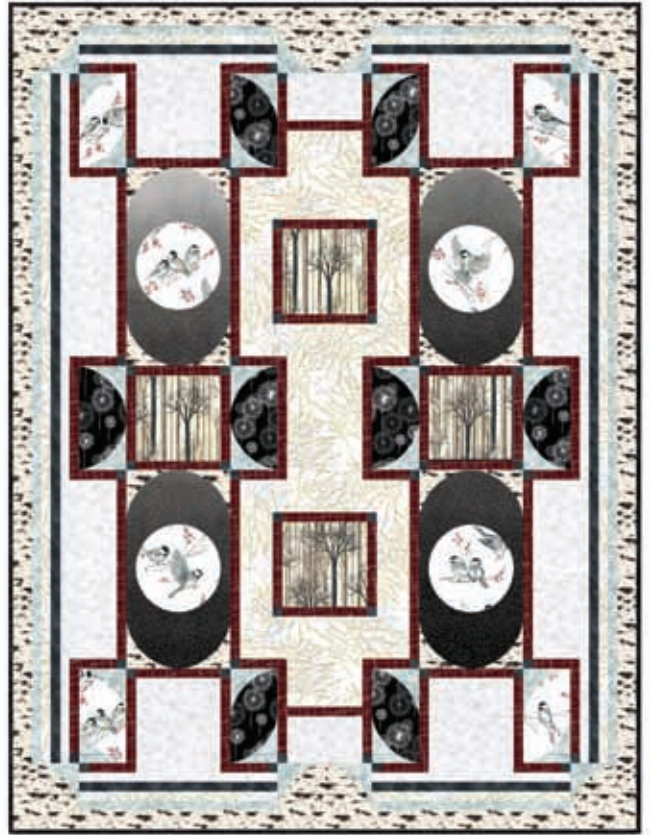

Fabric A Q7648 3S White Silver Center Background— $1\frac{3}{8}$ yards (Cut one $4\frac{1}{2}$ " x $11\frac{1}{2}$ " strip from remaining $5\frac{1}{2}$ " strip.)	First Cuts		Next Cuts	
	1	$8\frac{1}{2}$ " x 42 "	1	$8\frac{1}{2}$ " x $13\frac{1}{2}$ "
	1	$5\frac{1}{2}$ " x 42 "	2	$5\frac{1}{2}$ " x $8\frac{1}{2}$ "
	1	$4\frac{1}{2}$ " x 42 "	4	$4\frac{1}{2}$ " x $11\frac{1}{2}$ "
	2	4 " x 42 "	4	4 " x $19\frac{1}{2}$ "
	8	$1\frac{1}{2}$ " x 42 "	4	$1\frac{1}{2}$ " x $21\frac{1}{2}$ "

Fabric B Q7647 619S Warm Gray Silver Circle Background— $1\frac{3}{8}$ yards	Cuts	
	4	$11\frac{1}{2}$ " x $21\frac{1}{2}$ "

Fabric C L7360 134S Parchment Silver Quilt Background $1\frac{1}{8}$ yards	First Cuts		Next Cuts	
	1	$19\frac{1}{2}$ " x 42 "	4	$19\frac{1}{2}$ " x $4\frac{1}{2}$ "
	1	$5\frac{1}{2}$ " x 42 "	4	$9\frac{1}{2}$ " squares
			2	$5\frac{1}{2}$ " x $8\frac{1}{2}$ "
	2	$2\frac{1}{2}$ " x 42 "	4	$2\frac{1}{2}$ " x $9\frac{1}{2}$ "
	3	$1\frac{1}{2}$ " x 42 "	4	$2\frac{1}{2}$ " x $19\frac{1}{2}$ "
		2	$1\frac{1}{2}$ " x $13\frac{1}{2}$ "	
		4	$1\frac{1}{2}$ " x $11\frac{1}{2}$ "	
		8	$1\frac{1}{2}$ " x $6\frac{1}{2}$ "	

Fabric D Q7650 126S Birch Silver Tree Blocks $\frac{1}{2}$ yard	Cuts	
	4	$9\frac{1}{2}$ " squares "Fussy Cut"

Fabric E Q7646 3S White Silver Circles & Small Blocks 1 yard	Cuts	
	4	$10\frac{1}{2}$ " x $5\frac{1}{2}$ " "Fussy Cut"
	4	9 " circles "Fussy Cut" <i>Refer to page 5 for circle cutting instructions.</i>

Fabric F Q4412 4S Black Silver Small Blocks $\frac{3}{4}$ yard "Fussy Cut"	First Cuts		Next Cuts	
	1	$11\frac{1}{2}$ " x 42 "	4	$11\frac{1}{2}$ " x $5\frac{1}{2}$ "
	1	$10\frac{1}{2}$ " x 42 "	4	$10\frac{1}{2}$ " x $5\frac{1}{2}$ "

Lining (backing for Appliqué circles)— $5\frac{1}{3}$ yards
 $\frac{2}{3}$ yard Lining does not show. Batting— 75 " x 96 "

Fabric I P4324 5S Red Silver Sashing 1 yard	First Cuts		Next Cuts	
	20	$1\frac{1}{2}$ " x 42 "	8	$1\frac{1}{2}$ " x $19\frac{1}{2}$ "
			2	$1\frac{1}{2}$ " x $13\frac{1}{2}$ "
			4	$1\frac{1}{2}$ " x $11\frac{1}{2}$ "
			8	$1\frac{1}{2}$ " x $10\frac{1}{2}$ "
			28	$1\frac{1}{2}$ " x $9\frac{1}{2}$ "
			2	$1\frac{1}{2}$ " x $8\frac{1}{2}$ "
			16	$1\frac{1}{2}$ " x $5\frac{1}{2}$ "
		8	$1\frac{1}{2}$ " x $4\frac{1}{2}$ "	

Fabric G L7360 307S Snow Silver Small Blocks & Border $1\frac{3}{8}$ yards	First Cuts		Next Cuts	
	5	$5\frac{1}{2}$ " x 42 "	32	$5\frac{1}{2}$ " squares
	8	$1\frac{1}{2}$ " x 42 "	4	$1\frac{1}{2}$ " x $21\frac{1}{2}$ "

Fabric J Q7649 126S Birch Silver Outside Border $1\frac{1}{4}$ yard	First Cuts		Next Cuts	
	5	45 " x $2\frac{1}{2}$ "	$(45$ " runs parallel to selvage)	
	6	$2\frac{1}{2}$ " x 27 "		
	2	$5\frac{1}{2}$ " x $10\frac{1}{2}$ "		
	20	$5\frac{1}{2}$ " squares		

Fabric H P4323 92S Slate Silver Sashing Accents & Border $\frac{2}{3}$ yard	First Cuts		Next Cuts	
	11	$1\frac{1}{2}$ " x 42 "	4	$1\frac{1}{2}$ " x $21\frac{1}{2}$ "
			56	$1\frac{1}{2}$ " squares

Fabric K L7360 4S Black Silver Binding— $\frac{7}{8}$ yard	Cuts	
	8	$2\frac{3}{4}$ " x 42 "

Important Information

Before you begin read all instructions. Refer to project Cutting Chart, cut First Cuts strips as indicated in chart, then cut smaller pieces listed under Next Cuts from these strips. Use an accurate $\frac{1}{4}$ "-wide seam allowances to construct these quilts. Press seams in the direction of arrows, as they are indicated in each diagram.

Note: Check quilt on page 1 motif fabric direction prior to sewing units and rows together. Red arrow denotes direction of fabric in step illustrations.

Making the Curved Units

1. Fold one $5\frac{1}{2}$ " Fabric G square in half diagonally as shown. Press. Make thirty-two folded triangles.

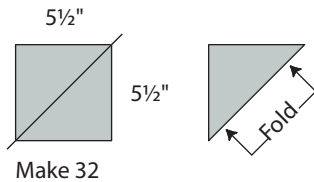

2. Place two folded triangles from step 1 on one $10\frac{1}{2}$ " x $5\frac{1}{2}$ " Fabric E piece as shown. Turn folded edge toward outside corner forming a gentle curve. Stitch close to folded edge to secure curve in place. Make four, two of each variation. Label these Unit 1A or Unit 1B.

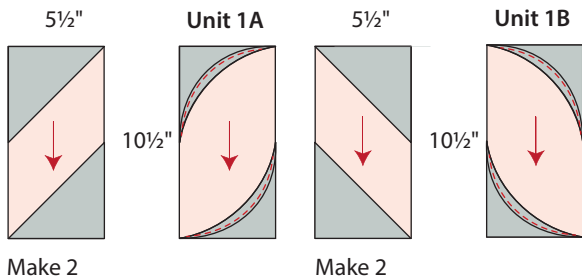

3. Place two folded Fabric G triangles from step 1 on one $10\frac{1}{2}$ " x $5\frac{1}{2}$ " Fabric F piece as shown. Turn folded edge toward outside corner forming a gentle curve. Stitch close to folded edge to secure curve in place. Make four, two of each variation. Label these Unit 2A & Unit 2B.

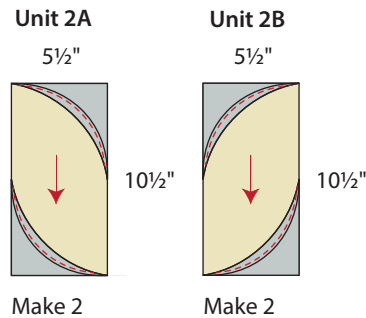

4. Place two folded Fabric G triangles on one $11\frac{1}{2}$ " x $5\frac{1}{2}$ " Fabric F piece as shown. Form curve and stitch in place. Make four, two of each variation. Label these Unit 3A & Unit 3B.

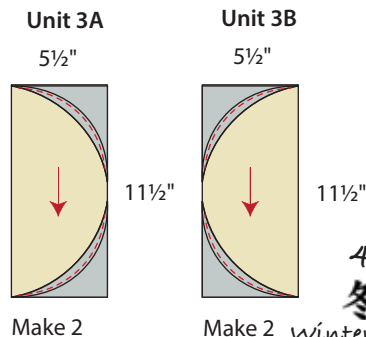

3. Place one folded Fabric G triangle from step 1 on one $5\frac{1}{2}$ " Fabric J square as shown. Turn folded edge toward outside corner forming a gentle curve. Stitch close to folded edge to secure curve in place. Make four, two of each variation. Label these Unit 4A & Unit 4B.

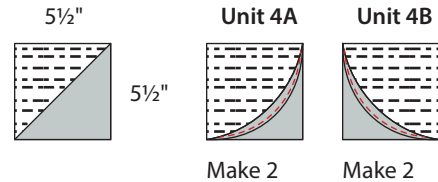

4. Place two folded Fabric G triangles on one $5\frac{1}{2}$ " x $10\frac{1}{2}$ " Fabric J piece as shown. Form curve and stitch in place. Make two, one of each variation. Label these Unit 5A & Unit 5B.

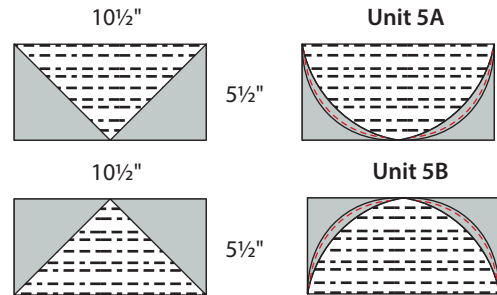

5. Fold one $5\frac{1}{2}$ " Fabric J square in half diagonally as shown. Press. Make sixteen folded triangles, eight of each variation.

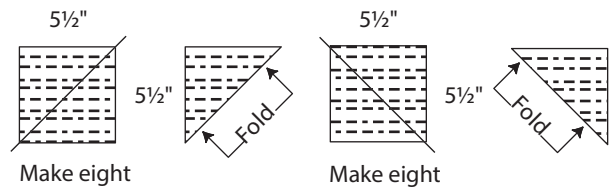

6. Place four folded Fabric J triangles on one $11\frac{1}{2}$ " x $21\frac{1}{2}$ " Fabric B piece as shown. Form curve and stitch in place. Make four and label these Unit 6.

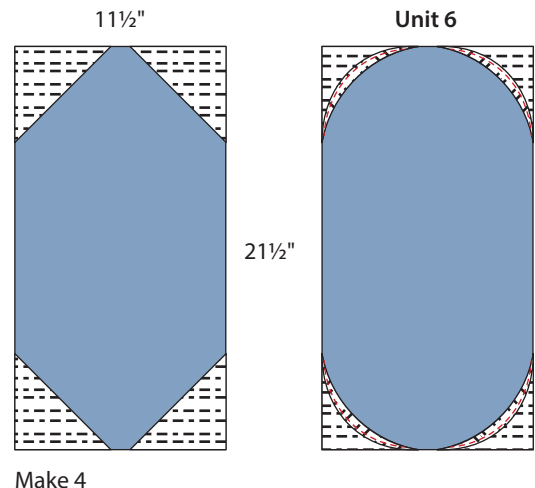

Adding the Appliqué

The finished 9" Fabric E circles for this quilt are "Fussy Cut" from motif bird fabric.

Appliqués are sewn to quilt by machine (without fusible web) or use your prefer appliqué method.

1. Trace quarter circle template on pattern paper or template plastic four times aligning placement lines to make a whole 9" circle pattern. Select the desired motif area to be featured in the circle. Trace around circle template on the wrong side of the fabric. The traced line will be your sewing line.

2. The lining will not show but it is recommended to match motif fabric background color. From lining piece, cut four 11" squares.

3. Place Fabric E marked piece right sides together with an 11" lining square. Sew on circle traced line. Cut unit approximately $\frac{1}{4}$ " from sewn line to allow for seam allowance. Make a slit in the center of the backing piece being careful not to cut the motif fabric. Turn right side out and press. Note: If additional dimension is desired add batting to the unit prior to sewing the circle. Sew on marked line. Trim batting close to stitching and fabric as noted above.

4. Center circle on one Unit 6 and pin in place. Stitch close to circle outside edge. Make four and label these Block 1.

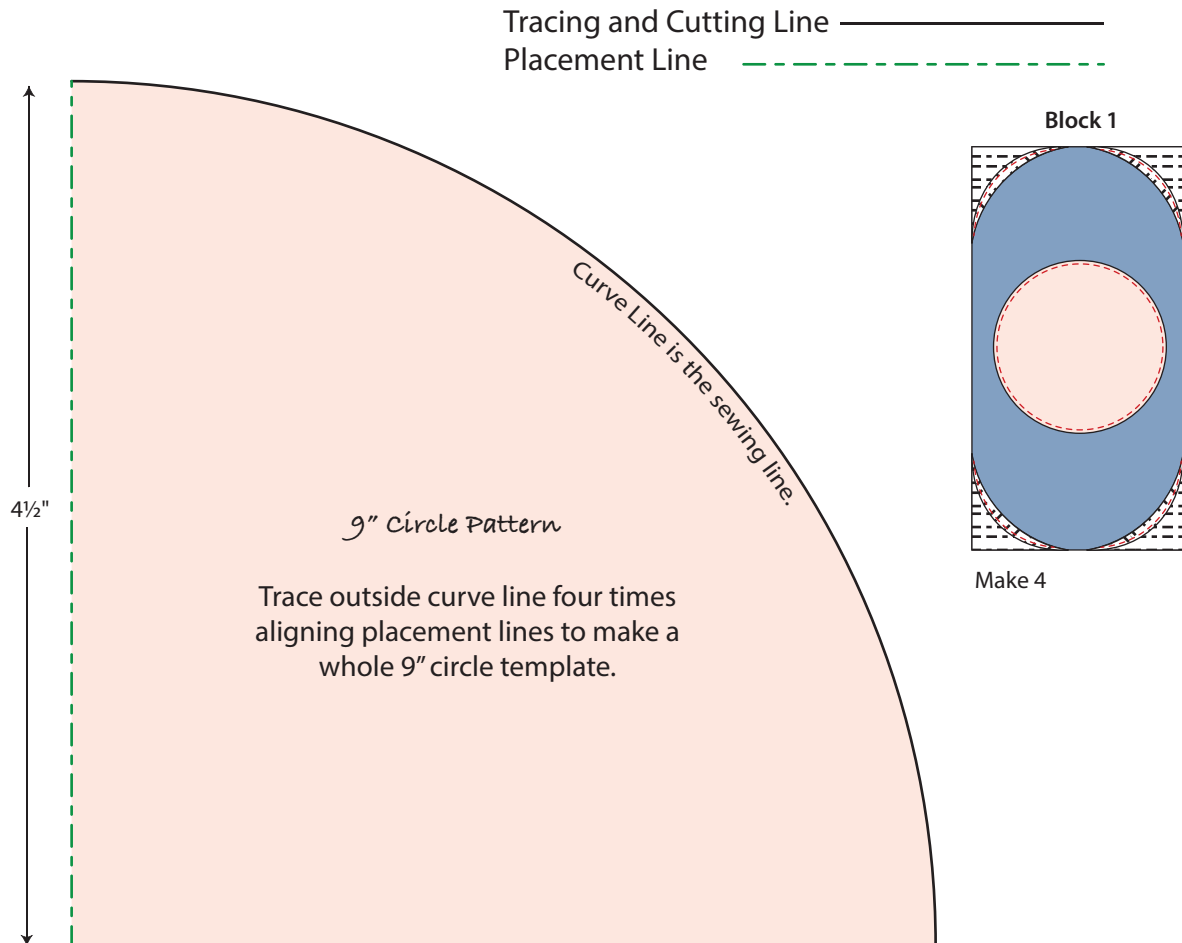

Making the Quilt

Vertical Rows 2 & 6

1. Sew one $1\frac{1}{2}$ " x $19\frac{1}{2}$ " Fabric I strip to one $19\frac{1}{2}$ " x $4\frac{1}{2}$ " Fabric C piece as shown. Press. Make four, two of each variation.

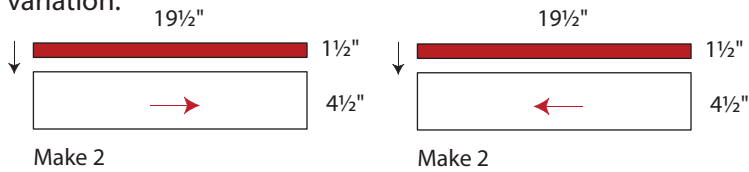

2. Sew one $1\frac{1}{2}$ " Fabric H square to one $1\frac{1}{2}$ " x $4\frac{1}{2}$ " Fabric I strip as shown. Press. Make eight. Sew one unit from step 1 between two units from this step. Press. Make four. Label these Unit 7A & B.

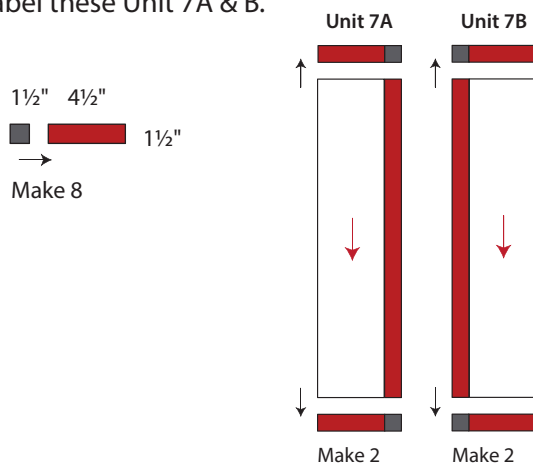

3. Refer to Quilt Layout Rows 2 and 6 on page 8. Refer to quilt page 1 for directional fabric placement. Arrange and sew together two of Unit 1A, two of Unit 7A, and one Unit 3A as shown. Press and label this Row 2. Re-

Making Vertical Rows 3 & 5

1. Sew one $9\frac{1}{2}$ " Fabric D square between two $1\frac{1}{2}$ " x $9\frac{1}{2}$ " Fabric I strips as shown. Press. Make four.

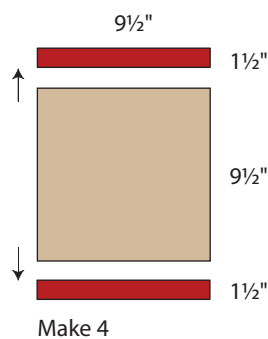

2. Sew one $1\frac{1}{2}$ " x $9\frac{1}{2}$ " Fabric I strip between two $1\frac{1}{2}$ " Fabric H squares. Press. Make eight. Sew one unit from step 1 between two units from this step as shown. Press. Make four. Label these Unit 8.

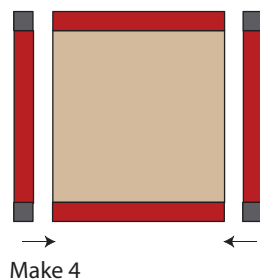
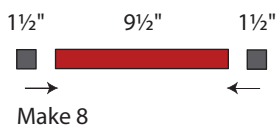

6
冬
Winter Zen
Garden Quilt

3. Sew one $9\frac{1}{2}$ " Fabric C square to one $1\frac{1}{2}$ " x $9\frac{1}{2}$ " Fabric I strip as shown. Press. Make four. Sew one $1\frac{1}{2}$ " Fabric H square to one $1\frac{1}{2}$ " x $9\frac{1}{2}$ " Fabric I strip. Press. Make eight. Sew one unit from this step between two sashing units. Press. Make four. Label Unit 9A & Unit 9B.

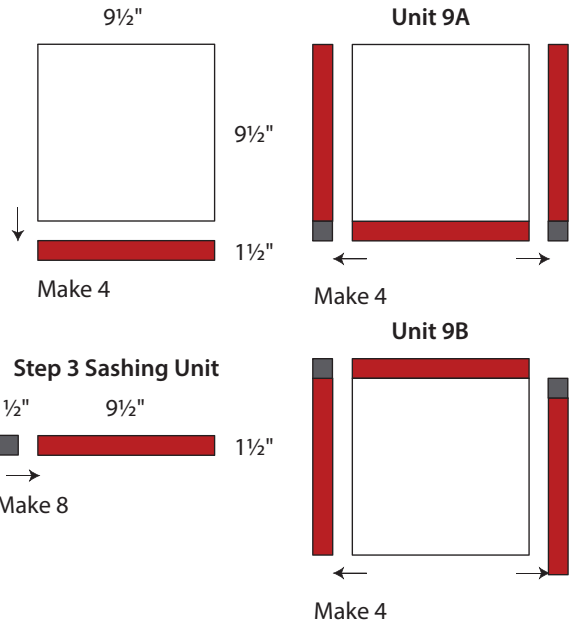

4. Refer to Quilt Layout on page 8 for Rows 3 and 5 layout. Refer to quilt page 1 for directional fabric placement. Arrange and sew together one of Unit 9A, two of Block 1, and one Unit 9B as shown. Press and label these Rows 3 and 5.

Making Vertical Row 4

1. Sew one $1\frac{1}{2}$ " Fabric H square to one $1\frac{1}{2}$ " x $4\frac{1}{2}$ " Fabric I strip as shown. Press. Sew one Unit 2A or Unit 2B to one unit from this step. Press. Make four, two of each variation.

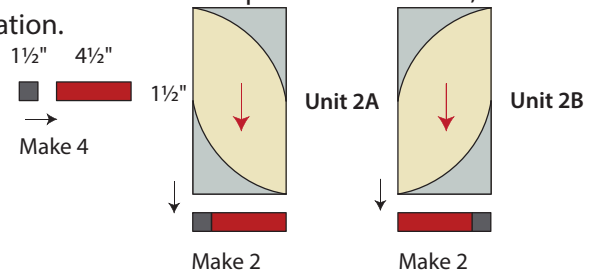

2. Refer to diagram below for directional fabric placement. Sew one $1\frac{1}{2}$ " x $8\frac{1}{2}$ " Fabric I strip between one $5\frac{1}{2}$ " x $8\frac{1}{2}$ " Fabric C piece and one $5\frac{1}{2}$ " x $8\frac{1}{2}$ " Fabric A piece as shown. Press. Make two.

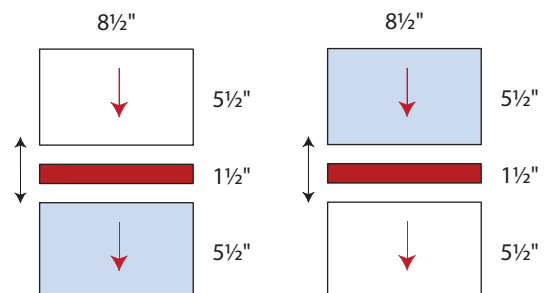

3. Sew one 1½" Fabric H square to one 1½" x 10½" Fabric I strip as shown. Press. Make four. Sew unit from step 2 between two units from this step. Press. Make two.

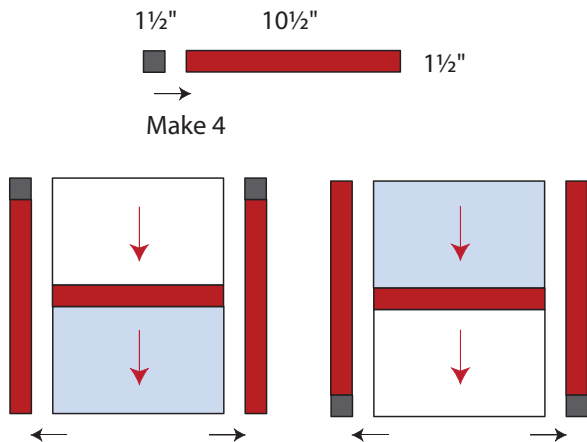

4. Refer to Quilt on page 1 for directional fabric placement in block. Sew one unit from step 3 between two units from step 1, one of each variation as shown. Press. Label these Block 2.

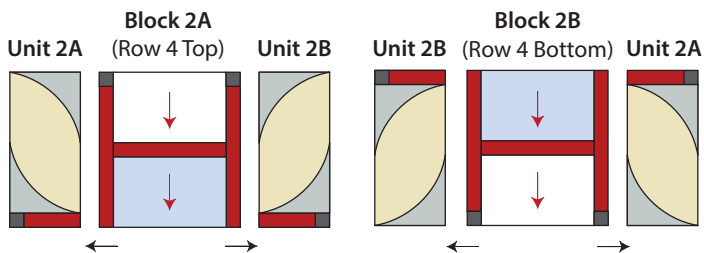

5. Sew one Unit 8 between two 4½" x 11½" Fabric A pieces as shown. Press. Sew two 1½" x 19½" Fabric I strips, two 4" x 19½" Fabric A strips, and unit from this step as shown. Press. Make two. Label units Block 3.

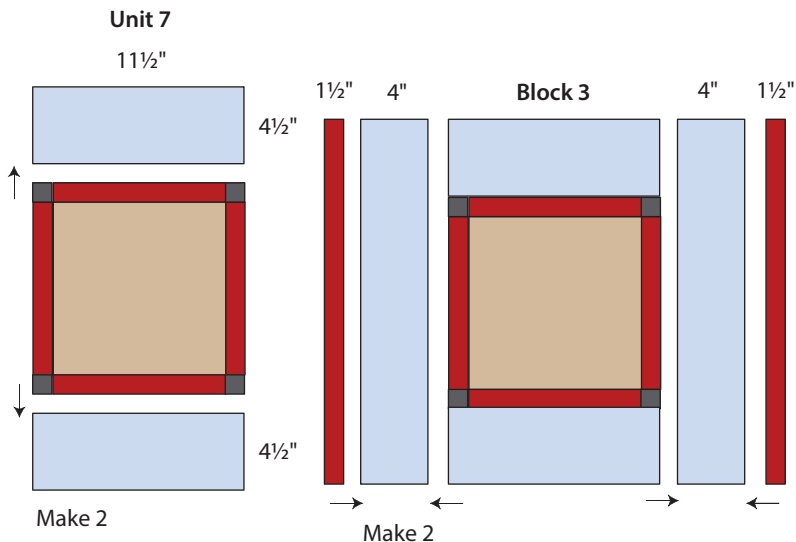

6. Sew one Unit 3 to one 1½" x 11½" Fabric I strip as shown. Press. Make four, two of each variation.

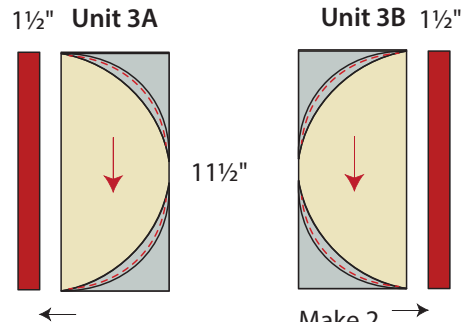

7. Sew one 1½" Fabric H square to one 1½" x 5½" Fabric I strip as shown. Press. Make four. Sew one unit from step 6 between two units from step 1 as shown. Press. Make two, one of each variation.

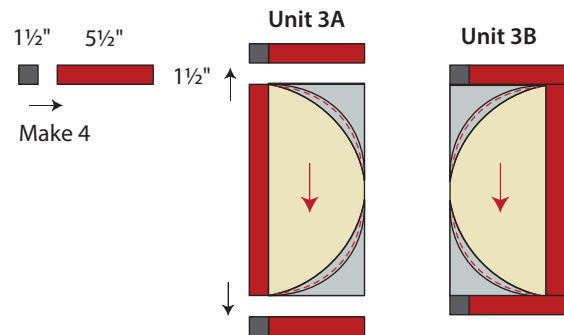

8. Sew one 8½" x 13½" Fabric A piece between one Unit 3B and one Unit 3A as shown. Press. Label these units Block 4.

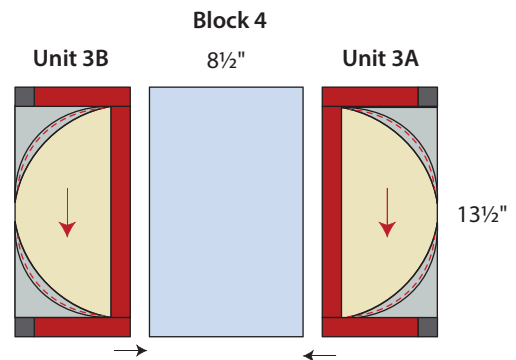

9. Refer to Quilt Layout on page 8 for Row 4 layout. Refer to quilt page 1 for directional fabric placement. Arrange and sew together two of Block 2, two of Block 3 and one Block 4 as shown. Press and label this Row 4.

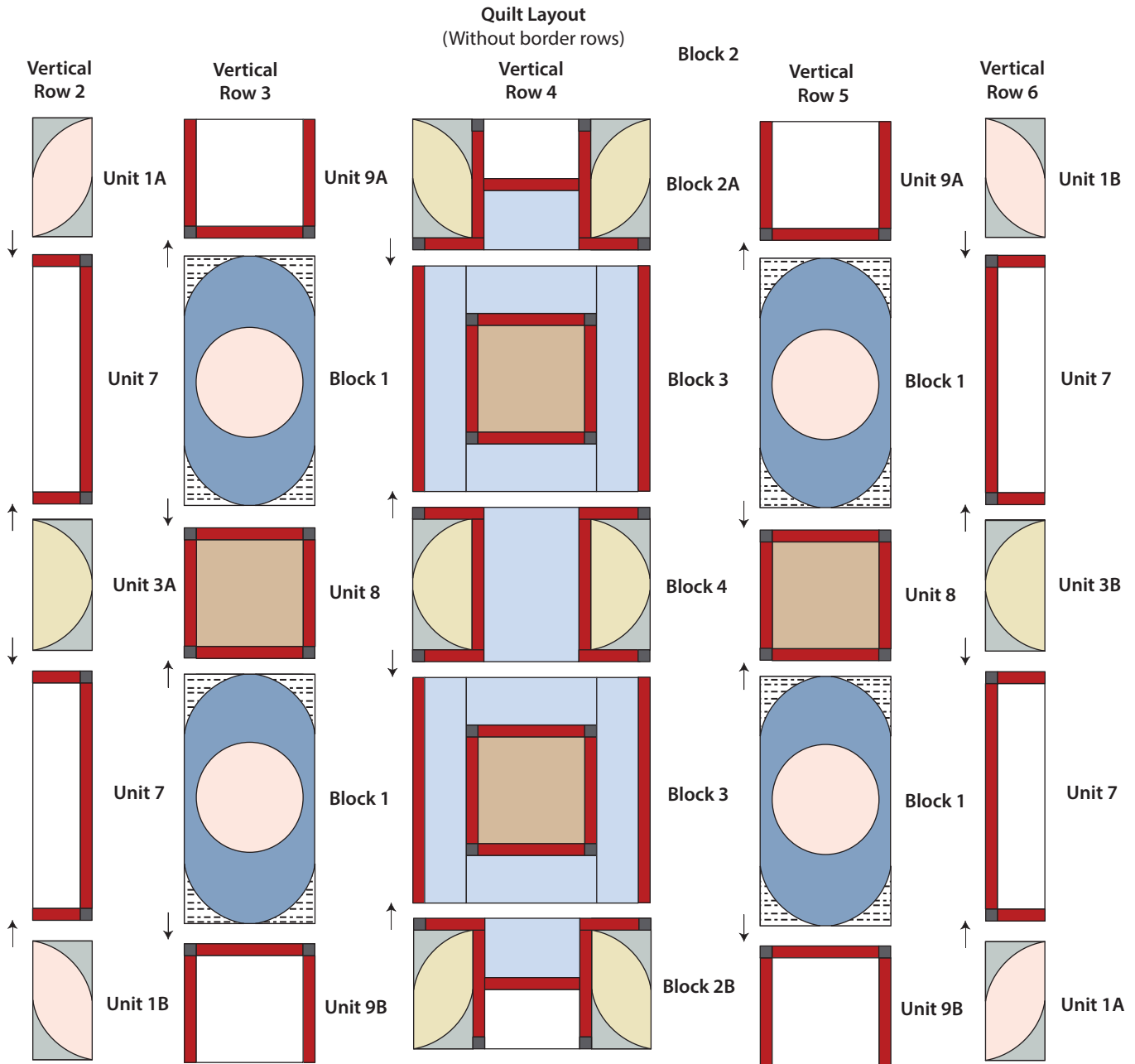

10. Referring to above layout, arrange and sew rows together. Press.

Making the Border Sections

1. Sew one $1\frac{1}{2}$ " Fabric H square to one $1\frac{1}{2}$ " x $10\frac{1}{2}$ " Fabric I strip as shown. Press. Make four.

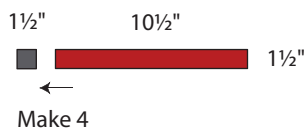

2. Sew one $1\frac{1}{2}$ " x $11\frac{1}{2}$ " Fabric C strip to one unit from step 1 as shown. Press. Make four, two of each variation.

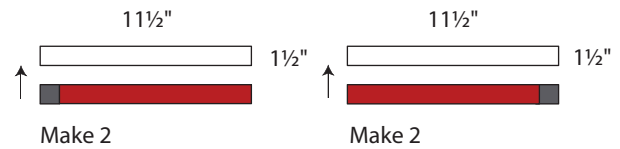

3. Sew one $1\frac{1}{2}$ " x $13\frac{1}{2}$ " Fabric C strip to one $1\frac{1}{2}$ " x $13\frac{1}{2}$ " Fabric I strip as shown. Press. Make two.

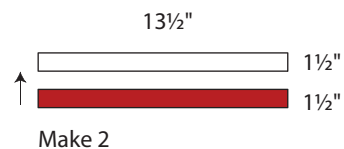

4. Arrange and sew together two units from step 2, one of each variation, two $2\frac{1}{2}$ " x $19\frac{1}{2}$ " Fabric C strips, and one unit from step 3 as shown. Press. Make two.

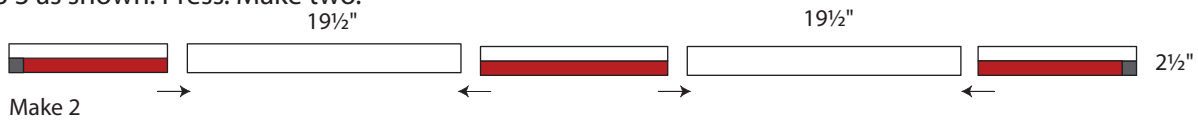

5. Sew $1\frac{1}{2}$ "-wide Fabric A strips end-to-end to make one continuous Fabric A strip. Press. Measure and cut two $1\frac{1}{2}$ " x $73\frac{1}{2}$ " strips. Repeat step to make two $1\frac{1}{2}$ " x $73\frac{1}{2}$ " Fabric G strips and two $1\frac{1}{2}$ " x $73\frac{1}{2}$ " Fabric H strips. Arrange and sew together one of each strip and unit from step 4 as shown. Press. Make two. Refer to quilt on page 1 and sew rows to sides of quilt center section. Press.

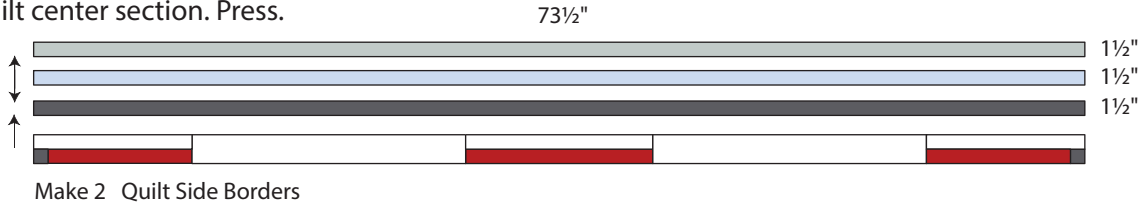

6. Sew one $1\frac{1}{2}$ " Fabric H square to one $1\frac{1}{2}$ " x $5\frac{1}{2}$ " Fabric I strip as shown. Press. Make eight. Sew one $1\frac{1}{2}$ " x $6\frac{1}{2}$ " Fabric C strip to one unit from step 4 as shown. Press. Make eight, four of each variation.

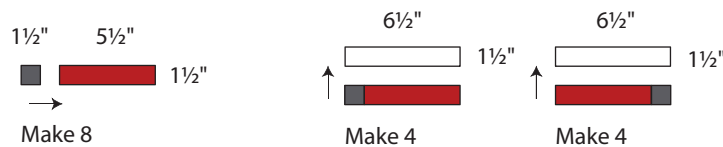

7. Sew one $2\frac{1}{2}$ " x $9\frac{1}{2}$ " Fabric C strip between two units from step 6, one of each variation. Press. Make four.

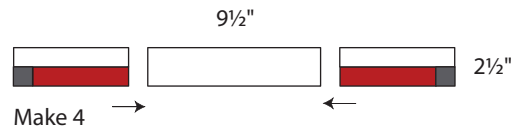

8. Sew one $1\frac{1}{2}$ " x $21\frac{1}{2}$ " Fabric G strip, one $1\frac{1}{2}$ " x $21\frac{1}{2}$ " Fabric A strip, one $1\frac{1}{2}$ " x $21\frac{1}{2}$ " Fabric H strip, and one unit from step 7 as shown. Press. Make four.

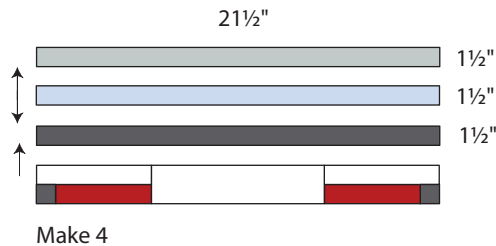

9. Arrange and sew together two of Unit 4A, two units from step 8, and one Unit 5 as shown. Press. Make two. Refer to quilt on page 1 and sew one unit to top of quilt and one unit to bottom of quilt. Press.

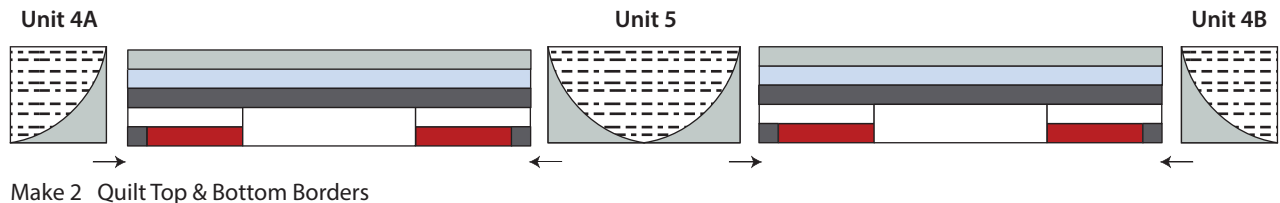

10. Sew five $2\frac{1}{2}$ " x 27" Fabric J strips end-to-end to make one continuous $2\frac{1}{2}$ "-wide Fabric J strip. Press. Measure quilt from side to side. Cut two $2\frac{1}{2}$ "-wide strips to this measurement. Sew to top, and bottom of quilt. Press seams toward border.

11. Sew five 45" x 2½" Fabric J strips end-to-end to make one continuous 2½"-wide Fabric J strip. Press. Measure quilt through center from top to bottom, including borders just added. Cut two 2½"-wide Fabric J strips to that measurement. Sew to sides of quilt and press.

Finishing the Quilt

1. Cut backing fabric piece into two equal pieces. Sew pieces together to make one 80" x 96". Trim backing to measure 75" x 96". Press.

2. Layer and baste backing, batting, and quilt top together. Hand or machine quilt as desired.

3. Sew 2¾" x 42" Fabric K strips (or your prefer binding width) strips end-to-end to make one continuous Fabric K strip. Bind quilt as desired.

